

US95 Plus Pushbutton

The circular shaped US95 Plus braille pushbutton meets all the requirements of the visually impaired. It is made up of four elements: switch body, illumination, pressel, and surround. This data sheet includes detailed information on each element and the options available for the US95 Plus pushbutton.

The character or symbol, known as the legend, provides clear identification. The legend and the halo (light created between the pressel and the surround) can be illuminated in a wide variety of colours.

SWITCH BODY

The switch body is the functional part of the pushbutton. The US95 Plus is available with Compact 3, Compact 3P and Compact 2 Micro switch bodies.

PRESSEL

The pressel is the faceplate of the pushbutton, and is available in a range of material finishes, including brushed stainless steel, mirror stainless steel, brushed brass and mirror brass. Standard US95 Plus pressels are moulded with opal polycarbonate.

There is an extensive range of pressel legends to choose from. All legends are 15mm high and tactile, with standard English braille dots below.

ILLUMINATION

Single, dual and bicolour+ LED illumination options are available for the US95 Plus. These illuminate both the legend and the halo. They are easily replaceable and available in blue, white, red, amber and green.

SURROUND

The surround is the element of the pushbutton which sits in front of the pressel and clicks into the switch body. US95 Plus pushbutton surrounds are available in a wide variety of material, depth and colour.

Standard material finishes include clear plastic, chrome, brass, satin chrome, black and green.

Image shows US95 Plus pushbutton with Compact 3 switch body, chrome surround, and brushed stainless steel pressel. Legend illuminated in blue. Legend illuminated in blue.



KEY FEATURES

- Large pressel which fits Compact range switch bodies.
- Extensive range of pressel legends to choose from with bespoke designs available on request.
- Legends are 15mm high and tactile with braille.
- Legend and halo illumination.
- Vandal resistant - meets EN81-71.
- Standard pressels are a stainless steel plate moulded with opal polycarbonate.
- Matching range including indicators, key switches and rocker switches.

Switch body | Jumbo & Jumbo P

The switch body is the functional part of the pushbutton. Both the Compact 3 and 3P switch bodies offer the full range of illumination options as well as all possible contact configurations.

Dimensions

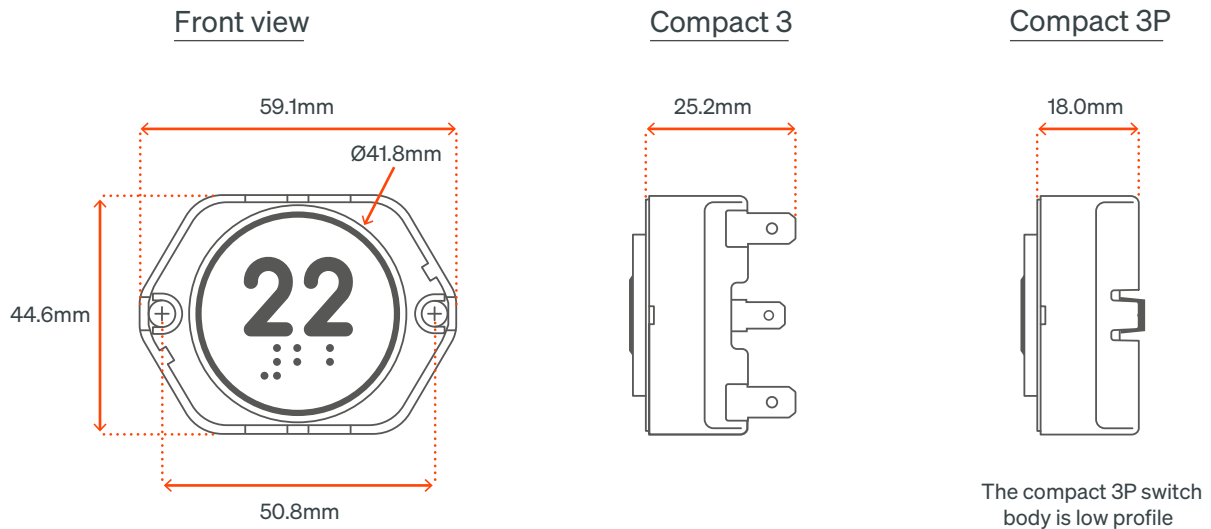

Technical details

Power (continuous)	2.5 watts (maximum)
Contact arrangements	2 Normally Open contacts
	2 Normally Closed contacts
	1 Normally Open contact and 1 Normally Closed contact

Environmental protection (IP rating)	EN60529 (IP54)
Vandal resistance	EN81-71
Code compliance	EN81-20, EN81-70

Dewhurst Compact 3 & Compact 3P switch bodies are designed and tested to last



over 10 million operations

Cutouts & stud positions

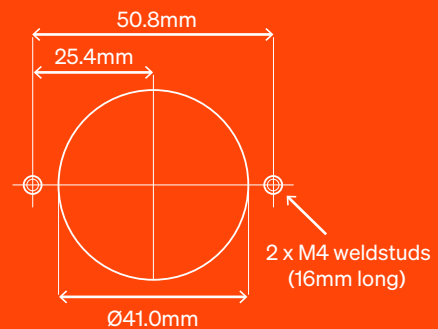

Pushbuttons with Compact 3 and Compact 3P switch bodies can be supplied loose or incorporated into stations. These have a vertical pitch of 50mm and a horizontal pitch of 60mm (Compact 3), or 80mm (Compact 3P), which means the switch body can be rotated 90 degrees.

If the pushbutton is supplied loose, spacers will be provided to accommodate the differing faceplate thickness.

Switch body | Compact 2 Micro

The switch body is the functional part of the pushbutton. The Compact 2 Micro switch body is available with one NO contact configuration. It also offers single, dual and bicolour illumination options.

Dimensions

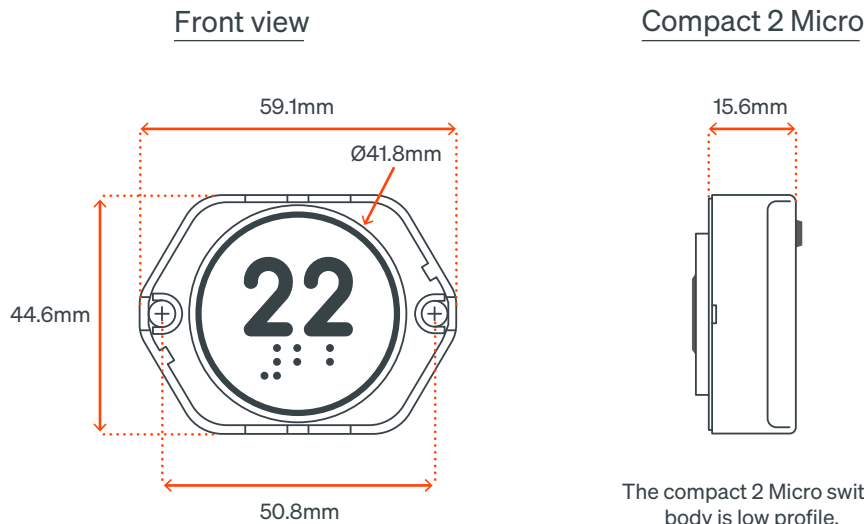

Technical details

Power (continuous)	2.5 watts (maximum)
Contact arrangement	1 Normally Open contact
Environmental protection (IP rating)	EN60529 (IP54)
Vandal resistance	EN81-71
Code compliance	EN81-20, EN81-70

Dewhurst Compact 2 Micro switch bodies are designed and tested to last

over 1 million operations



Cutouts & stud positions

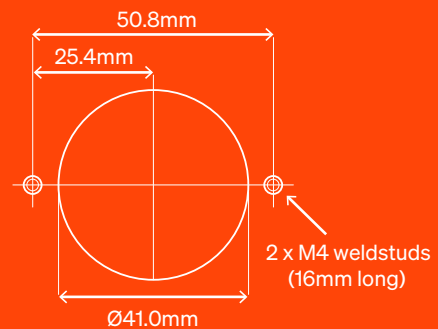

Pushbuttons with Compact 2 Micro switch body can be supplied loose or incorporated into stations. These have a vertical pitch of 50mm and a horizontal pitch of 60mm, which means the switch body can be rotated 90 degrees.

If the pushbutton is supplied loose, spacers will be provided to accommodate the differing faceplate thickness.



Illumination

There are a wide range of interchangeable and easily replaceable LED illumination options available for Dewhurst pushbuttons. All options illuminate both the legend (character or symbol) and the halo (circle of light created between the pressel and the surround).

The US95 Plus offers a choice of single, dual and bicolour+ illumination, all of which are available with Compact 3 and Compact 3P switch bodies. The Compact 2 Micro switch body comes with single, dual or bicolour illumination.

LED colours are available in blue, white, red, amber and green.



Single illumination

Before call acceptance	After call acceptance
 <p>Both the legend and the halo are non-illuminated</p>	 <p>The legend and halo are both illuminated at full brightness of any colour</p>

Dual illumination

Before call acceptance	After call acceptance
 <p>Both the legend and the halo are illuminated at 10% of full brightness of any colour</p>	 <p>The legend and halo are both illuminated at full brightness of the same colour</p>

Bicolour+ illumination

Before call acceptance	After call acceptance
 <p>Both the legend and the halo are illuminated at full brightness of any initial colour</p>	 <p>The legend and halo are both illuminated at full brightness of a different colour</p>

Note: Bicolour+ illumination isn't available with the Compact 2 Micro switch body.

Technical details

LED current	20mA (typically)
LED voltage ($\pm 15\%$)	12V DC, 24V DC, 110V AC

Pressel

The pressel (the faceplate of the Dewhurst pushbutton) is available in a range of standard material finishes. There is an extensive range of pressel legends to choose from. All legends are 15mm high and tactile, with standard English braille dots below. Bespoke characters are available on request.

Material finishes

Brushed stainless steel



Mirror stainless steel



Brushed brass



Mirror brass



Standard US95 Plus pressels are moulded with opal polycarbonate, but other colours are available on request.

Surround

The surround is the element of the pushbutton which sits in front of the pressel and clicks into the switch body. Dewhurst pushbutton surrounds are available in a wide variety of material, depth and colour.

Material finishes

Standard material finishes include clear plastic, chrome, brass, satin chrome, black and green.

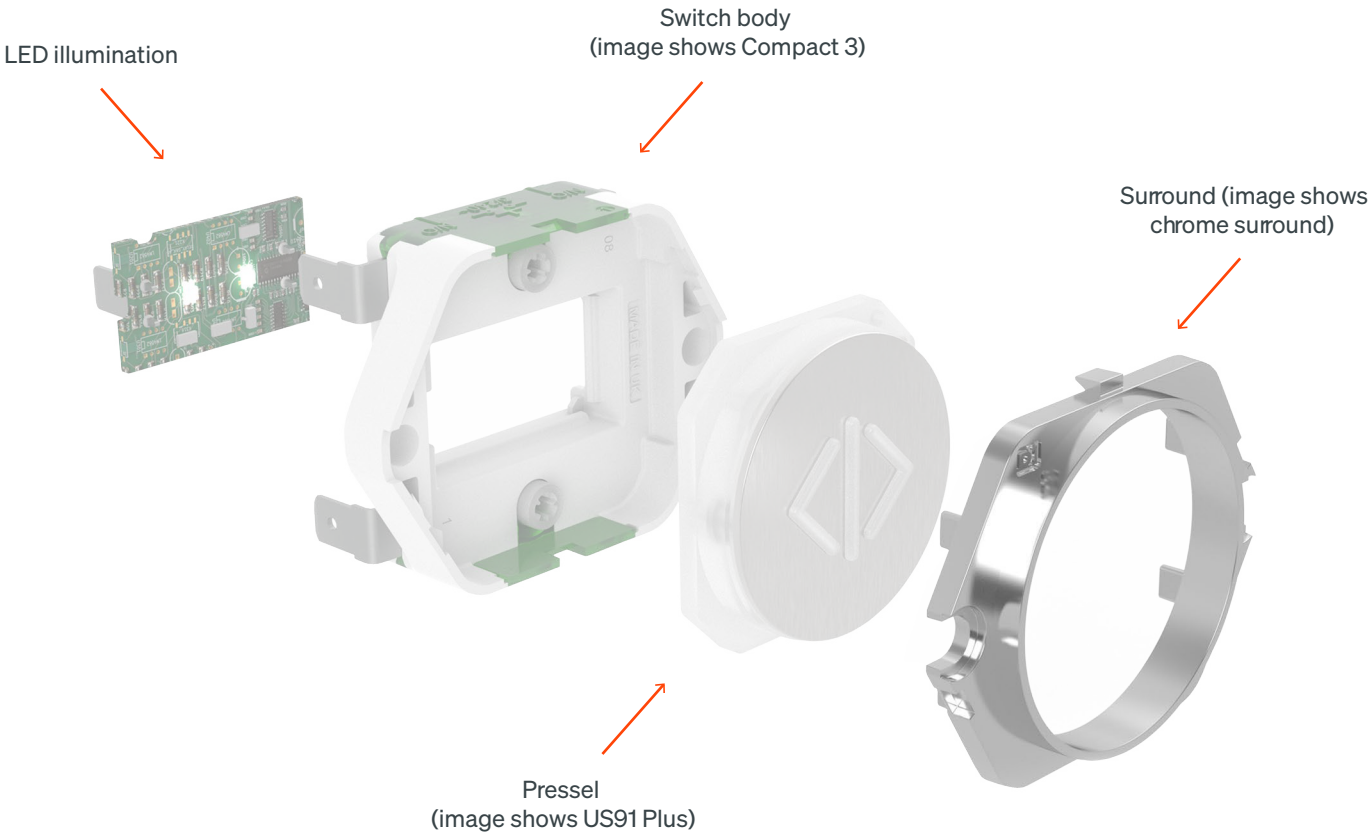

Surround depths

All measurements are the protrusion through the faceplate.

EN/B44	AUS	EN81-70 Exit	Long neck
(a) 4.5mm	(b) 6mm	(c) 7mm	(d) 12mm, 14mm OR 22mm

Cleaning your Dewhurst pushbutton

Many Dewhurst lift products are made of polycarbonate. The weatherproof pushbutton is highly durable and vandal resistant, but plastic parts can be damaged by aggressive cleaning agents.

Recommended guidance



Clean with a cotton cloth and warm water before applying the cleaning product.



Use PH-neutral or slightly acid cleaning products only (including aromatised ones).



Ethylic alcohol, isopropyl alcohol or ethylene glycol based multipurpose cleaning products and dish soaps are suggested. Dilute the cleaning product in warm water and apply using a wet cotton cloth.



Grease, glue and paint may be removed with ethylic alcohol or isopropyl alcohol.

DO NOT USE

- X Abrasive cleaning agents
- X Cleaning agents at high temperatures
- X Antibacterial detergent
- X Sharp tools to remove dirt (chewing gum, glue, etc.)
- X Solvents based with Ketones, benzene, methanol, toluene (methylbenzene or phenyl methane)
- X Alkaline and ammonia based cleaning agents or ones containing citrus

DO NOT leave cleaning agents on the parts for long periods of time: remove immediately after cleaning using a damp cotton cloth.