

VL11 Gatelock

Installation Guide

FIGURE 1
VL11 RIGHT HAND

VL11 GATELOCK RIGHT HAND
i.e. WITH DOOR CLOSING TO
RIGHT FACING THE LIFT WELL

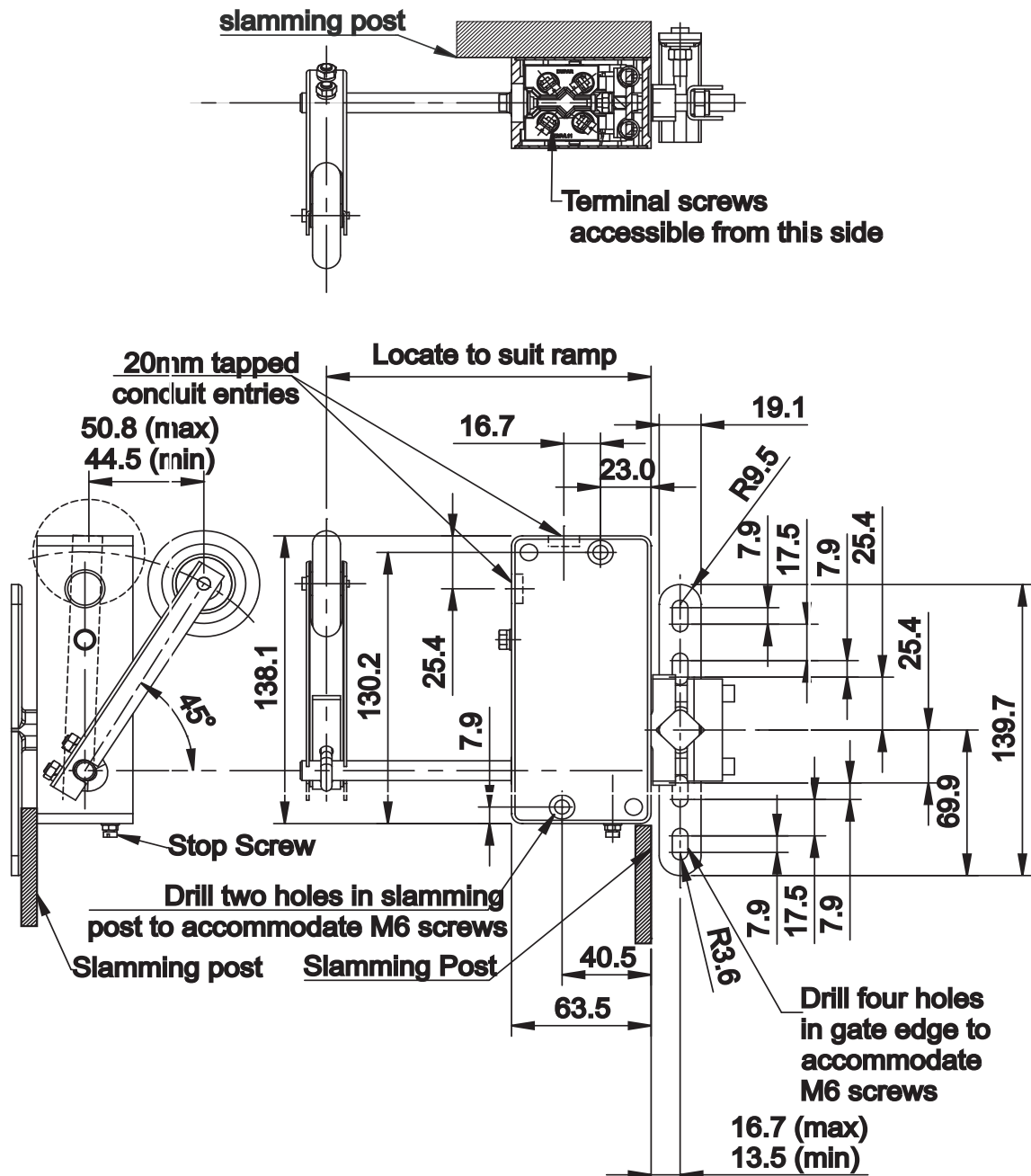
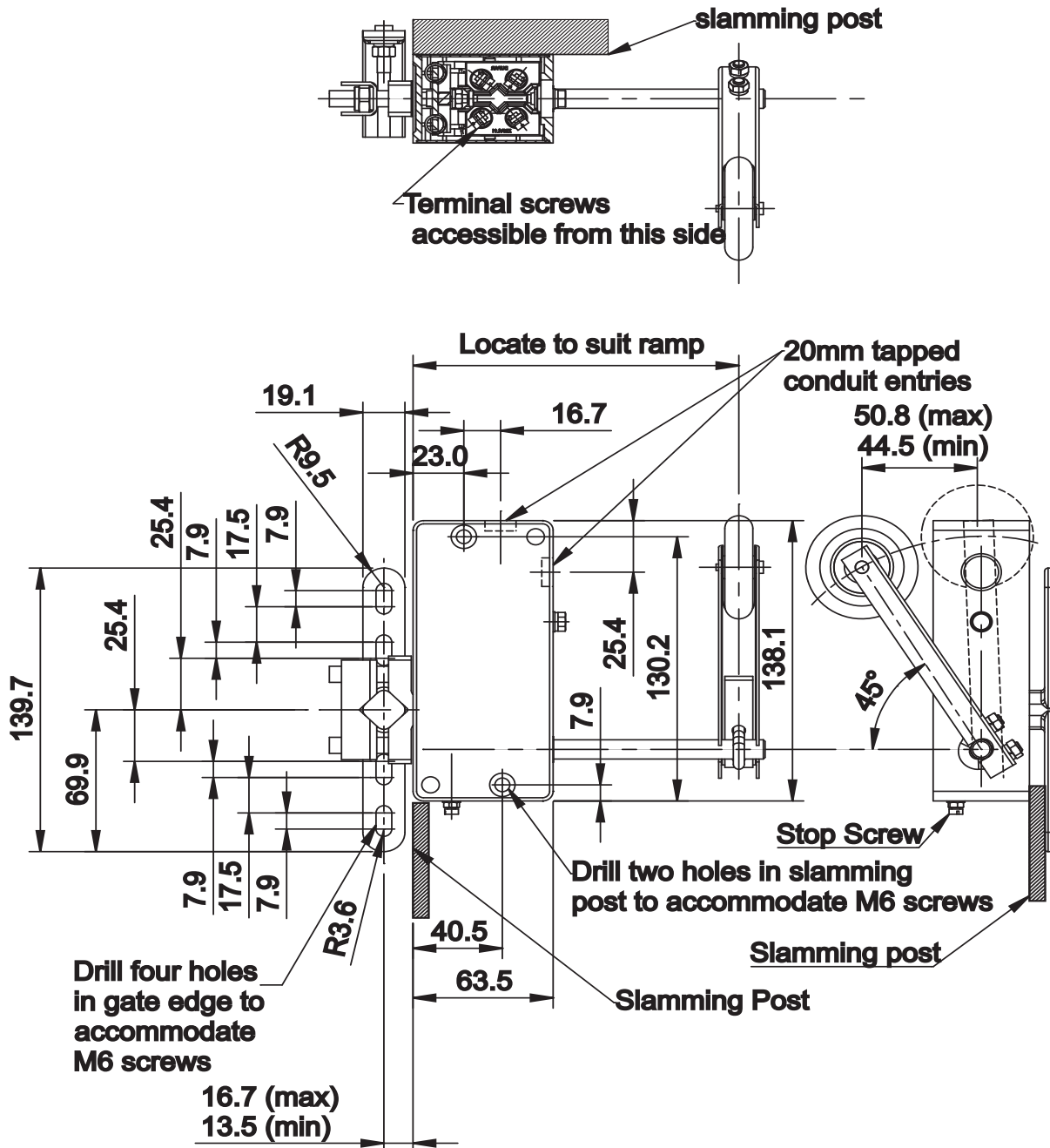

FIGURE 2
VL11 LEFT HAND

VL11 GATELOCK LEFT HAND
i.e. WITH DOOR CLOSING TO
LEFT FACING THE LIFT WELL



Application

The VL11 Gatelock is robustly constructed for installation on lift landings with side closing single collapsible gates or single sliding doors.

Operation is in accordance with BS5655: Part 1 : 1986, except for Clause 7.7.3.1.1 and Appendix F.1.

For use as like-for-like replacement only, in accordance with BS5655: Parts 11 & 12 : Clause 2.2

Environment

VL11 is suitable for application in all normal indoor locations. Abnormal locations involving water spraying or splashing, chemical fumes and ignitable or explosive gases or dusts, require more detailed consideration. If in doubt concerning location or installation, consult the manufacturers.

Operation

The gatelock should be used in conjunction with a suitable retiring ramp. (Dewhurst Type FR21 is suitable for this application).

When the landing door/gate is closed, the beak enters the lock and engages with an insulated cam which carries contacts that then complete a primary circuit (A). When the ramp clears the lock roller the operating arm of the gatelock falls forward allowing the locking plate to move downward, trapping the beak in position. The beak locking action is accompanied by the completion of a secondary circuit (B), but only if the primary circuit has been made.

Installation

The gatelock must be installed with the beak and the operating arm below the lock centre line and with the conduit entries at the top. Check that the gatelock has been assembled to suit the handing required.

The gatelock must be mounted with the beak entry face in line with the slamming post but not in front of it. Use dimensional data supplied to mark the fixing positions for the lock on the slamming post and also mark the centre of the beak carrier on the gate edge channel. Drill fixing holes in slamming post and secure lock with two M6, rustproof, countersunk-head screws together with spring-washers and nuts.

If the gatelock is to be fitted to a collapsible gate, mark and drill the gate edge channel with four holes to accommodate M6 screws at the spacing indicated on Figure 1, positioning them 1.6mm from the top of the slots in the beak carrier. If a sliding door is to be used, obtain from the door supplier details of his recommended method of fitting the gatelock.

Fit the gatelock and beak as appropriate and check that the beak lines up with the entry in the lock. Adjust height of the beak carrier as necessary using slotted holes and make horizontal adjustment by moving the beak along the square shank of the carrier. Tighten all fixing screws and nuts. Slacken nuts on the operating arm clamp. Move the arm along the shaft until the roller centre line coincides with the centre line of the retiring ramp.

Set the operating arm at 45° to the lock body, with the roller above the centre line and towards the lift. Set the retiring ramp to move the roller a minimum of 44.5mm and a maximum of 50.8mm towards the lock body as illustrated. Tighten nuts on the clamp to compress fully the spring-washers but not more. Do not over-tighten the nuts.

If, when the operating arm is positioned on the shaft an excessive length remains beyond the arm, cut-off surplus leaving between 6.3mm and 19.0mm of length.

Electrical Connection

Ensure main and control supplies are isolated.

Remove front cover from the lock. Utilise one or two 20mm tapped conduit entries to bring wires into the gatelock. Ensure conduit termination is tight and secure. If flexible conduit is utilised, a separate earth wire must be installed in the conduit and must be securely connected to a suitable earth terminal in the electrical installation. Plug unused conduit entry.

Connect primary circuit using beak contact terminals A and secondary circuit using contact terminals B. Connect earth wire to terminal E. See Figure 3.

Check that the cables do not impede movements of the mechanism and that the springs controlling the locking plate are correctly located.

Replace front cover and tighten securing screws.

Contacts

Both sets of contacts are self-aligning and have a self-cleaning action with positive knock-off feature.

FIGURE 3

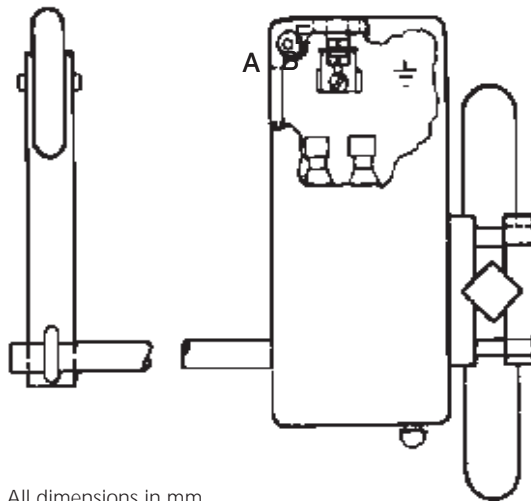

All dimensions in mm

Notes:

1. Roller operating force 0.45kgf.
2. No cantilever load to be applied to shaft.

