

# VL10/20/30 Gatelock

## Installation Guide

### CAUTION

1. **SWITCH OFF** the mains supply before any installation, maintenance or repair work is carried out.
2. **DO NOT** work on live equipment unless it is essential to do so, in which case extreme care must be taken to avoid electrical shocks, including the use of rubber mats.
3. Installation, maintenance or repair must only be carried out by a competent person who is trained on this equipment.
4. Replace all covers on completion of work and ensure the unit is safe for installation and use.

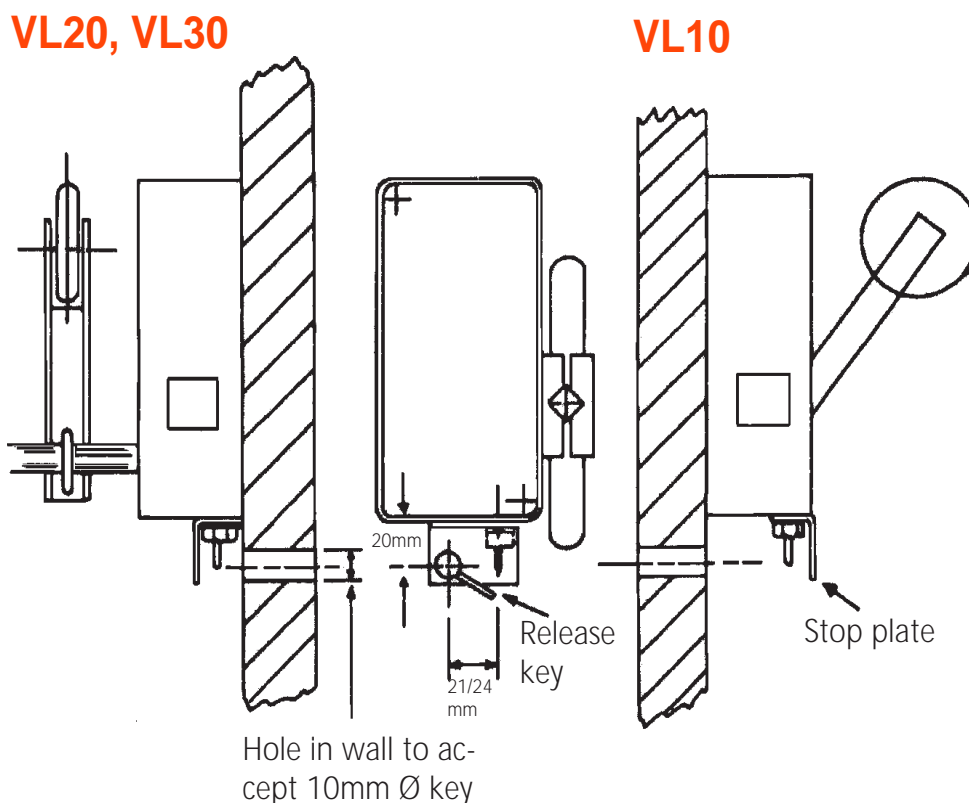

## **Installation**

1. Loosen nut and position key stop plate to suit type of lock.
2. Drill hole through wall to accommodate 10mm i.d. sleeving, in position dimensioned relative to the lock box.
3. Cut length of sleeving to suit wall thickness and insert in hole. Fit a ferrule to the landing side hole entrance.

**Note:** Sleeving and ferrule are to be supplied by user.

## **Safety**

The user is reminded of his responsibility to ensure that the diameter of the access hole for the release key must be small enough to prevent the insertion of bicycle chains etc. The above figure shows the recommended, method of installation. It is important that the hole be off-centre in relation to the release pin to prevent operation by straight rods etc. easily available to juveniles.

It is further recommended that the access hole be covered by a lockable plate to prevent unauthorised tampering.